

4 Cleaning the weighing platform

Maintenance of the weighing platform is restricted to regular cleaning.

Cleaning the exterior

- Water jet up to 60 °C.
- Usual household cleaning agents: use disinfectants and cleaning agents only in accordance with the stipulations and instructions of their producers.
- Corrosive environment: it is essential to remove corrosion-initiating substances at regular intervals.

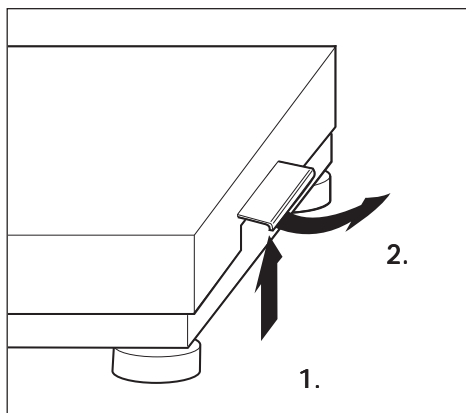

Cleaning the interior

- Remove dirt and deposits inside the weighing platform at regular intervals after taking off the load plate.

With DCC weighing platforms, to remove the load plate raise the two side handles (1.) vertically then swing outward (2.).

- Blow out dirt or
- wash out with water jet of moderate power.

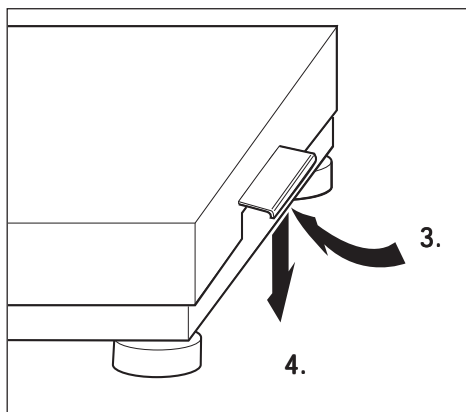

- Replace load plate.
After replacing the load plate of DCC weighing platforms, swivel the handles inward (3.) then engage in original position (4.). The handles must be in the bottom position and be vertical.
After correct engagement of the handles, it should not be possible to lift off the load plate.

Contents

| | | |
|---|--------------------------------------|---|
| 1 | Declaration of conformity | 2 |
| 2 | Cautionary notes | 2 |
| 3 | Operating limits | 3 |
| 4 | Cleaning the weighing platform | 4 |
| 5 | Optional equipment | 5 |

1 Declaration of conformity

We, **Mettler-Toledo (Albstadt) GmbH**
 Unter dem Malesfelsen 34
 72458 Albstadt

do hereby declare with undivided responsibility that the products

DB30sT/DB60sT
 DCC150sT/DCC300sT
 from serial number: 2040015

to which this declaration refers, comply with the following standards:

EN 45501
 EN 50081-1
 EN 50082-1
 EN 60950

According to the Council Directive governing regarding electromagnetic compatibility 89/336/EEC and the Council Directive dealing with electrical equipment for use within certain voltage limits 73/23/EEC.

Albstadt, April 3, 1995 Mettler-Toledo (Albstadt) GmbH

2 Cautionary notes



- Never operate in hazardous areas.
- Never operate in areas hazarded by gases, vapors, mists or dusts!

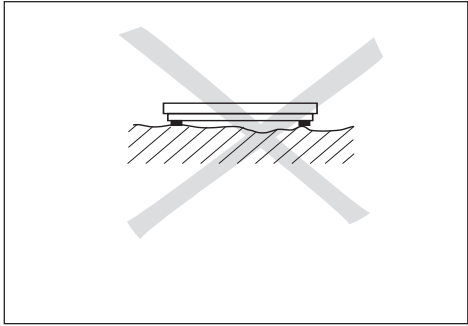

Selecting the location

- The sub-floor must be capable of safely supporting the weighing platform at the support points when it is carrying the maximum load.
- The sub-floor must be so stable that no vibrations appear in weighing work. This also applies when the weighing platform is installed in conveying systems and the like.

3 Operating limits

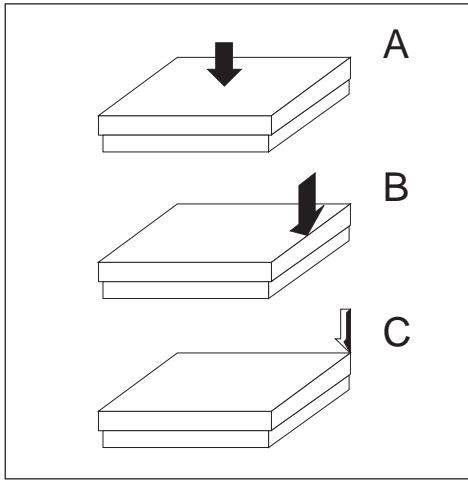

The weighing platforms have an extremely rugged construction so that no damage will result if the maximum weighing load is exceeded on the odd occasion.

Depending on the type of loading, the static load capacity, i.e. the maximum admissible load is as follows:

| Load | DB30sT DB60sT | DCC150sT DCC300sT |
|----------------------|------------------|----------------------|
| Central (A) | 120 kg | 500 kg |
| Side (B) | 80 kg | 300 kg |
| One-sided corner (C) | 40 kg | 150 kg |

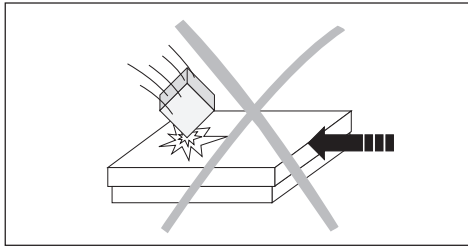

- Avoid falling loads, shocks and lateral impacts.

Operating instructions

METTLER TOLEDO MultiRange DB30sT / DB60sT DCC150sT / DCC300sT Stand scales

METTLER TOLEDO

nefton
Ζύγιση
Σήμανση
Συμμόρφωση

Νεϋτων Τεχνολογίες ΑΒΕΕ

Γέρακα 113, Τ.Θ. 67934

15344 Γέρακας

Τηλ: 210 6654544

Fax: 210 6654545

marketing@nefton.gr

www.nefton.gr

Mettler-Toledo (Albstadt) GmbH, D-72458 Albstadt, Germany, Tel. (0 74 31) 14-0, Fax (0 74 31) 14-232

A Mettler-Toledo Ges.m.b.H., 1100 Wien, Tel. (01) 604 19 80, Fax (01) 604 28 80
AUS Mettler-Toledo Ltd., Victoria 3207, Tel. (3) 646 45 51, Fax (3) 645 39 35
B N.V. Mettler-Toledo S.A., 1651 Lot, Tél. (02) 3340211, Fax (02) 3781665
CH Mettler-Toledo (Schweiz) AG, 8606 Greifensee, Tel. (01) 944 45 45, Fax (01) 944 45 10
CN Mettler-Toledo (Shanghai) Ltd., Shanghai 200233, Tel. (21) 470 3932, Fax (21) 470 3351
D Mettler-Toledo GmbH, 35353 Giessen 11, Tel. (0641) 507-0, Fax (0641) 5 29 51
DK Mettler-Toledo A/S, 2100 Copenhagen Ø, Tel. (39) 29 04 00, Fax (39) 29 04 26
E Mettler-Toledo S.A.E., 08038 Barcelona, Tel. (93) 223 22 22, Fax (93) 223 02 71
F Mettler-Toledo s.a., 78220 Viroflay, Tél. (1) 30 97 17 17, Fax (1) 30 97 16 16
HK Mettler-Toledo PacRim Ltd., Kowloon, Hongkong, Tel. 724 23 48, Fax 724 23 49
I Mettler-Toledo S.p.A., 20026 Novate Milanese, Tel. (02) 33332.1, Fax (02) 35 62 973
J Mettler-Toledo K.K., Takarazuka 665, Tel. 797 74 2406, Fax 797 74 2641
N Mettler-Toledo A/S, 1008 Oslo 10, Tel. (22) 30 44 90, Fax (22) 32 70 02
NL Mettler-Toledo B.V., 4000 HA Tiel, Tel. (03440)11311*, Fax (03440) 20530
S Mettler-Toledo AB, 120 08 Stockholm, Tel. (08) 702 50 00, Fax (08) 642 45 62
SGP Mettler-Toledo (S.E.A.) Pte. Ltd., Singapore 0513, Tel. 0065 778 67 79, Fax 0065 778 66 39
TH Mettler-Toledo (Thailand), Bangkok 10310, Tel. 719 64 80-87, Fax 719 64 79
UK Mettler-Toledo Ltd., Leicester, LE4 1AW, Tel. (0116) 235 7070, Fax (0116) 236 6399
USA Mettler-Toledo Inc., Worthington, Ohio 43085, Tel. (614) 438-4511, Fax (614) 438-4755
USA Mettler-Toledo, Inc., Hightstown, NJ 08520-0071, Tel. (609) 448-3000, Fax (609) 586-5451
For all other countries: Mettler-Toledo AG, VI, 8606 Greifensee, Tel. 01/944 22 11, Fax 01/944 31 70

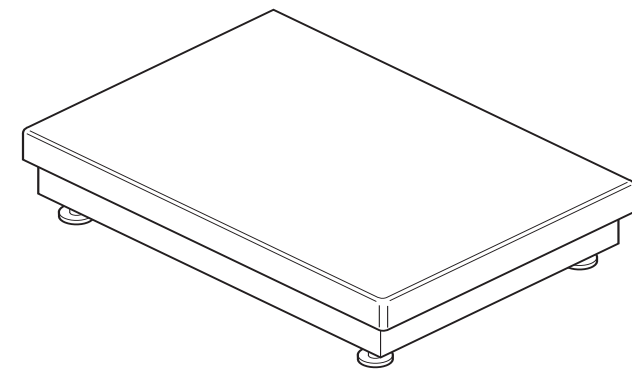

5 Optional equipment

| | Order number | |
|--|--------------|----------|
| | DB30sT | DCC150sT |
| | DB60sT | DCC300sT |
| Bench stand | | |
| Stable frame construction, two feet with casters, one fixed foot with locking screw, height approx. 560 mm | | |
| – black, plastic coated | 503 631 | 504 853 |
| – stainless steel | 503 632 | 504 854 |
| Roller track | | |
| 8 steel-clad rollers, motion lengthwise, stainless steel | 503 640 | 504 852 |